

Schäffer



TELESCOPIC WHEEL LOADERS

Performance redefined



MADE FOR MORE.

SCHÄFFER

For over 60 years, we have been developing loaders to meet individual requirements. Customer satisfaction has made us what we are today: one of the most capable and successful suppliers of farm loaders, wheel loaders and telescopic wheel loaders ever. Every day our employees create new, customised solutions. Every Schäffer loader is the result of years of experience and innovative thinking. Our products set the standard in terms of the highest possible reliability and durability. You can rely on Schäffer for lower costs throughout the whole operating life, and for performance, safety and driving comfort for many years to come.

SCHÄFFER TELESCOPIC WHEEL LOADERS: THE FUTURE OF PERFORMANCE.

When it comes to articulated telescopic loaders, Schäffer machines are the most successful in their class. Precision performance on any terrain, with lifting heights and loads that you will not find in comparable machines from our competitors. The compact design, characteristic of all Schäffer loaders, makes them easy to use particularly in

hard-to-reach areas. Add user-friendly controls found in all our models, and you have the perfect material handling solution. All loaders have the renowned Schaeffer reliability whilst our design engineers have focused on rugged, modern styling to match the powerful performance of the machines.



2630 T SLT 18.5 kW (25 HP)



3650 T 37 kW (50 HP)
42 kW (58 HP)



3650 T SLT 37 kW (50 HP)



4670 T 48.6 kW (66 HP)



5680 T 55 kW (75 HP)



6680 T 55 kW (75 HP)



8620 T 75 kW (102 HP)
95 kW (129 HP)



9640 T 105 kW (143 HP)



9660 T 130 kW (177 HP)
150 kW (204 HP)



Schäffer corporate film:
schaeffer.de/about-us

Also available as electric loader

23e T
schaeffer.de/en/23et



**OPERATING EFFICIENCY
WITHOUT COMPROMISES**



SCHÄFFER TELE WHEEL LOADERS: THE FLEXIBLE ALL-ROUNDERS

Schäffer tele wheel loaders offer a perfect combination of performance, comfort and reliability, and are suitable for operations of all kinds. The hydrostatic traction drive delivers high thrust forces coupled with very low fuel consumption.

The machine is very simple and intuitive. The view of the attachments is excellent. The comfortable seating position guarantees relaxed and productive work at all times for the driver.

Schäffer loaders not only increase productivity, but are also genuinely fun to drive. The mode of operation and handling are very similar to that of a conventional wheel loader. And it is correspondingly easy for a driver to adjust to a Schäffer tele wheel loader. After just a short learning curve, the driver will really appreciate the additional lifting height and reach.

Especially with the larger machines from the 8620 T-3 up, it makes sense to look more closely at the different versions of the working hydraulics. The simplest variant is a gear pump whose power is already sufficient to meet many requirements. There are also heavy-duty gear pumps or flowsharing hydraulics to choose from.

Another option is load-sensing work hydraulics with high performance and excellent efficiency.

HTF: MAXIMUM THRUST, EVEN WHEN IN HIGH GEAR

HTF, or 'High Traction Force', automatically regulates the thrust so the loader can supply the highest possible thrust even in a high gear. HTF uses a new axial piston-bent axis motor that regulates speed automatically depending on the traction. This is particularly useful in an uphill position as the driver does not have to switch to first gear.

HTF comes into its own when digging into aggregate material - if more thrust is required, the hydraulic motor adapts automatically, without the driver having to interfere manually. This means most of the work can be done in fast gear, increasing driving comfort and speeding up work. All Schäffer wheel loaders with Z kinematics are equipped and delivered with the HTF-drive as standard.

Benefits:

- Very high thrust forces
- No need to manually shift down a gear when going uphill
- Even at high speed the maximum thrust is always available, e.g. when driving in muck heaps
- Enhanced driving comfort, faster working

2630 T SLT

HTF  SPT 



Video 2630 T SLT:
[schaeffer.de/en/videos](https://www.schaeffer.de/en/videos)

2630 T SLT: COMPACT HELPER WITH AN ENORMOUS REACH

The Schaeffer 2630 T SLT is one of the most compact telescopic wheel loaders on the market. Combining smallest dimensions with a generous reach, the unique machine offers greatest versatility. Featuring a narrow 1.41 m width and a low 1.98 m height, it is the ideal machine for working inside buildings. Lifting 1.6 tonnes to a 3.72 m height and turning through a tight 1.24 m inner circle, the compact telescopic wheel loader is an agile workhorse that performs dependably in confined space.

The compact 2.7 t machine is powered by an 18.5 kW (25 HP), 3-cylinder low-emission diesel engine from Kubota that requires no emission aftertreatment. The Kubota is one of the highest-torque engines in this powerband and sources its power from a 1.7-litre cubic capacity, developing its maximum torque at fuel-efficient 1,500 rpm whilst running quiet and at reduced consumption rates. The standard-fit 510 bar high-pressure drive accelerates the loader rapidly to 20 kph, developing a high thrust and offering plenty of agility and driving pleasure. The thrust is controlled automatically by the HTF feature and efficiency is enhanced by the electronic SPT ground drive. Furthermore, the loader is available both with protective roof or full cab.



3650 T / 3650 T SLT: TELESCOPIC WHEEL LOADER TAILORED TO YOUR NEEDS

Buyers who opt for a Schäffer telescopic wheel loader with a 3.6 - 3.8 t operating weight can choose between two engines, two maximum speeds, two cabs and two build heights – a choice that allows everybody to customize the machine to their specific needs.

The engine is a Kubota of either 50 or 58 HP. The powerful high-pressure drive accelerates the machine to 20 kph or 30 kph as an option. Apart from that, the 3650 T is available either with a protective roof or a cab for convenient and year-round use.

Standout feature of the 3650 T SLT is its particularly low-profile build height of 2.10 m which allows the machine to pass through low entrance doors. Further benefits are its low centre of gravity and straightforward cab access.

All models feature an impressive 3.85 m lift height which makes filling high-sided mixer tubs or trailers a doddle. Another standard feature of the 3650 T and 3650 T SLT is the ECO Mode which reduces engine speed automatically when the machine is travelling a longer distance without the operator changing gears – a unique feature in this class that translates into optimum fuel efficiency and a smooth ride.



4670 T-3



4670 T-3: THE COMPACT TELESCOPIC WHEEL LOADER WITH HIGH STANDARDS

The 4670 T-3 offers an ideal combination of thrust and lifting height in a compact package. The newly designed HTF drive supplies enormous traction force, drawing on the 480 bar of pressure in the drive system and improved hydraulic efficiency. With automatic control, the full traction force

is also available in high gear. The machine's maximum speed is 20 kph, with a 30 kph option available which can be certified for road use if specified.

When it comes to their technical details, Schaffer's compact telescopic wheel loaders more than measure up. Wear and maintenance-free Ferro-Form sliding elements in the telescopic boom, alongside the 7 t heavy-duty axles will ensure that your loader provides years of problem-free service. The articulated/pendulum joint and the oil-immersed multiple disc brake are both maintenance-free.

The 4670 T-3 is well-powered with a 48.6 kW (66 HP) engine, so it can handle challenging tasks, and offers more agility and greater driving fun.



ELECTRONICALLY REGULATED DRIVE OFFERING MORE COMFORT

Our new Kubota motor offers the highest possible torque in its class and is unique in the market of these loaders due to an electronically regulated drive – SPT or 'Schaffer Power Transmission'. The drive is adapted to the torque of the diesel engine, for a multitude of advantages: operating costs decrease as the diesel fuel consumption is reduced. Hill starts are a lot easier as the start-up assistant helps prevent the vehicle moving backwards.

The optional potentiometer acts as a cruise control. The loader keeps a constant speed automatically and independently from the motor speed – especially convenient when working with fodder dosing devices, straw distributors, mulchers or brooms.

Additionally, there are several new safety functions, for example protection from overheating and motor over-revving protection, making working with the loader safer and more reliable. SPT is standard on the **2630 T SLT, 3650 T, 3650 T SLT, 4670 T-3, 5680 T-3, 6680 T-3, 8620 T-2** and **8620 T-3** is available as an option for the **9600** series.

Benefits:

- Higher efficiency, lower fuel consumption and reduced operating costs
- Extra safety functions including overheating and over rotation protection to make the loader safer and more reliable
- 'Start up assistant' to make hill starts easier
- Different parameters for different drive characteristics
- Optional potentiometer that works to maintain a constant speed regardless of the motor speed. This is particularly useful when working with feed dosing units, straw spreaders, mulchers or brooms (using pedal control on 9640 T-3 and 9660 T-2)
- Greater agility and more driving fun!

PURE ERGONOMICS



ERGONOMICS AT ITS BEST

Driver comfort was our top priority when designing the cabin of the 4670 T-3. A range of features contribute to a very comfortable work environment, so the driver can feel fresh, even after long working days. All operating and control instruments are clearly laid out and user-friendly, and easily accessed from the comfortable seat with impressive legroom. The generous use of glass delivers perfect visibility for working and manoeuvring. The third control circuit is integrated in the joystick, with no need to change the handle to operate the additional control circuit.



Perfect view upwards with roller blind

STANDARD ON 4670 T-3 CABIN:



Padded armrest behind joystick



Switch bar, electric plug



Multifunctionele joystick Multifunctional joystick



Bottle holder, battery switch



5680 T-3

The 5680 T-3 pivot steered telescopic wheel loader offers maximum comfort for long working days. The machine has a larger cabin in the standard height. The enclosed cabin and quiet-running diesel engine means noise levels are low too.

The 5680 T-3 has got a Deutz turbo engine with 55 kW (75 HP). The hydrostatic drive combines the best controllability and highest pushing power, and since all components of the drive train are perfectly matched, the fuel is converted into power sparingly and effectively. The standard hydraulic fan drive ensures quiet operation.

The maximum lifting height is 4.74 m.



The cabin offers more space and optimised all-round visibility.

6680 T-3

HTF  SPT  eco Mode 



Video 6680 T:
[schaeffer.de/en/videos](https://www.schaeffer.de/en/videos)

6680 T-3: THE NEW MEASURE

With its working weight of 5.8 t to 6.3 t, the 6680 T-3: is the smallest loader in the professional class. The loaders are driven by the latest generation 55 kW (75 HP) Deutz turbo diesel engine. It meets the requirements of the exhaust gas level stage V by using a diesel oxidation catalyst and a diesel particle filter. Because all the components in the hydrostatic drive are perfectly matched to each other, fuel consumption is converted into performance economically and effectively. The standard hydraulic fan drive reduces noise development. It is also available with an optional reverse function. The maximum driving speed of the 6680 T-3 is up to 40 kph, so that even interplant uses can easily be handled.

The 6680 T-3 is equipped with an SCV-Plus cabin. With this the machines set new standards in its class in terms of driving ergonomics, space and all-round visibility. A lower version that provides more flexibility in terms of overhead clearance is also available.

THE SCV-PLUS CABIN



ERGONOMICS AND COMFORT AT THE HIGHEST LEVEL

Our 6680 T-3 and 9660 T-2 range of telescopic wheel loaders benefit from the SCV-Plus cabin. Even at first glance, the tidy dashboard, ergonomic operating elements and the new colour co-ordinated range of switches show that this is the highest quality.

SCV stands for 'Silence, Comfort, View'. In the development of the SCV-Plus cabin, these ideas have been taken one step further. The operating elements are arranged in a more ergonomic way. The joystick is more comfortable to hold, additional functions speed up how you work. The extensive glass area offers the very best all-round visibility.

The ignition switch, along with the control system for the air-conditioning and heating systems is housed in a new console right next to the joystick. Additional, larger air outlets and removable side panels ensure the perfect supply of fresh air. With the SCV-Plus cabin, the driver has a completely new feeling of ergonomics and comfort – nothing to stand in the way of a long working day.



THE SCV-PLUS CABIN IN DETAIL



Joystick with expanded functionality



Ignition switch, controls for the heating and optional air-conditioning system are easy to reach



Additional, larger air outlets for perfect air circulation / optimised range of switches



12 Volt socket for charging mobile devices / 3-pin device socket



Side panels can be lifted out



Information display in the B-column for the exhaust gas system

8620 T-3 / 9640 T-3

HTF  SPT  ECO Mode  SDCT 
only 9640 T-3

THE FUTURE OF TELESCOPIC WHEEL LOADERS STARTS HERE

The 8620 T-3 and the 9640 T-3 represent the start of a new era of telescopic wheel loaders. The machines define the future of this powerful loader class and offer an unparalleled level of performance, ergonomics and efficiency. Sounds good? That's because it is!

Our brand new comfort cabin Plus offers significantly enhanced driving comfort and an extended range of functions. A wealth of new assistance systems improves work efficiency. At the same time, safety is boosted through monitored loading processes and an optimised all-round view.

With over 30 years of experience in the design and engineering of telescopic wheel loaders, we have combined our expertise with your ideas to create a new generation. The result: two new telescopic wheel loaders that make your farm work more comfortable and more efficient.

We know your telescopic wheel loader is often the machine that does the most work on your farm. This is due not least to its versatile application possibilities. And this is the reason why your new telescopic wheel loader deserves only the best in terms of safety, efficiency, ergonomics and comfort. Our 8620 T-3 and the 9640 T-3 models set new standards in all these areas and are your reliable partners on the road to economic success.





Smartphone holder

10" touch screen

Round instrument panel with level indicators and tell-tale lights

Side window can be opened 180°, easily accessible door and window release

USB sockets

Clearly arranged operating panel

Sockets

Electronic SRS joystick

Ignition key

Cup holder

The height and tilt of the steering column can be adjusted by a pedal

Parking brake

Fully suspended pedals

THE CABIN: YOUR NEW COMMAND CENTRE

Enter the large and inviting comfort cabin Plus, which is much more spacious than its predecessors thanks to a wider design. It is equipped with a 10-inch touch-screen, which makes operation more user-friendly than ever. Control your telescopic wheel loader effortlessly and intuitively. The colour-structured switch concept facilitates navigation. An additional soft-touch control panel featuring large buttons ensures quick access to the most frequently used functions. The steering column is easy to adjust, and all the pedals have an ergonomic and suspended design – a distinct advantage for both controlling and cleaning.

Large window in the roof with roller blind

Radio

Ambient lighting

Soft-touch control panel

Upward view: Next to the generously dimensioned roof window is the soft-touch control panel with quick access to the most important functions, the ambient lighting and the radio.

EFFICIENT WORKING MADE EASY

Discover the various user profiles for the working hydraulics, individually adapted to your loading activities. The "fast mode" enables fast loading processes, while the "slow mode" makes precise tasks, such as moving pallets, child's play. Control these functions intuitively via the touchscreen, just like the optional assistance systems that make working with the loader even easier. These include:

- Oil volume regulation for the auxiliary hydraulics
- Floating position of the telescopic arm
- Shake function of the tool
- Automatic tool positioning
- Automatic tool emptying
- Dynamic vibration damping
- Automatic reversing fan

OPERATING YOUR LOADER: NOW MORE INTUITIVE THAN EVER

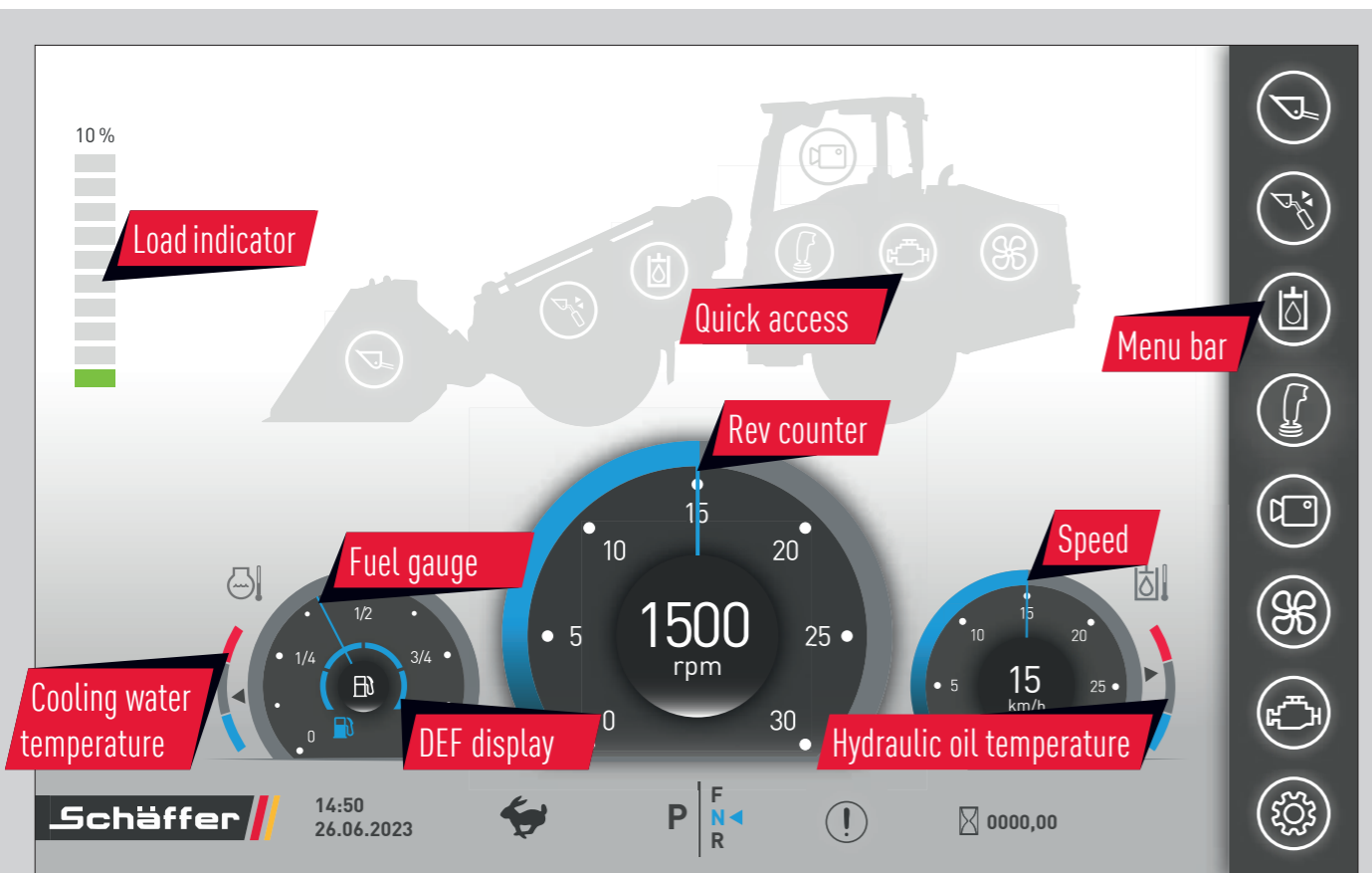

Everything at a glance: The new start screen provides the operator with a clear view of the machine status. The various settings can be accessed via the quick access icons on the loader at the top or via the menu bar on the right.

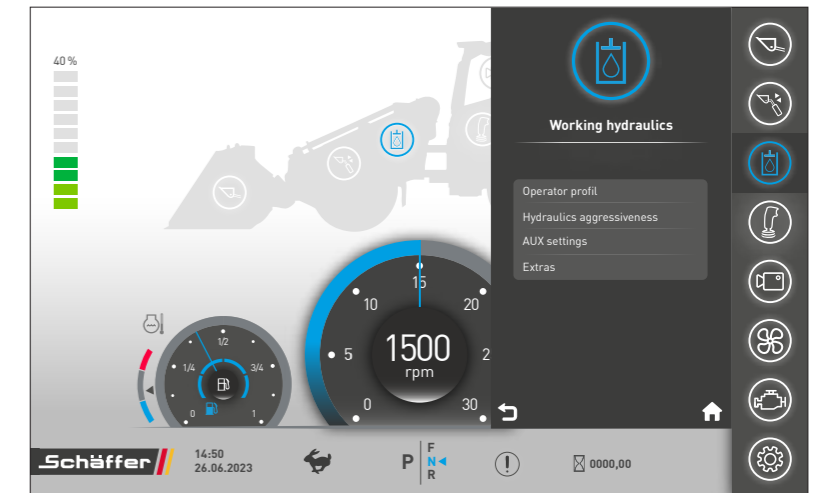

- Preview, layout will differ in the series version. -

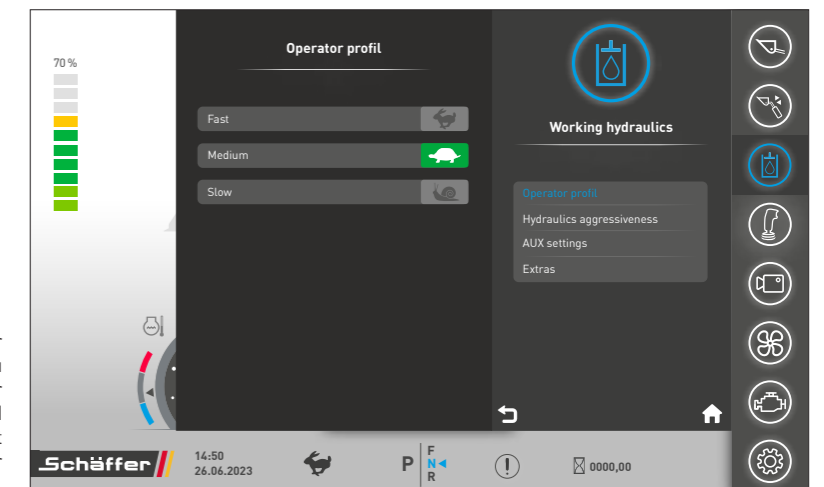

- Preview, layout will differ in the series version. -

Example of the menu guidance for the working hydraulics: The sub-menu featuring the various options appears after selecting the button on the right-hand side or via the quick access icon. Different user profiles can be selected and further hydraulic options applied here.

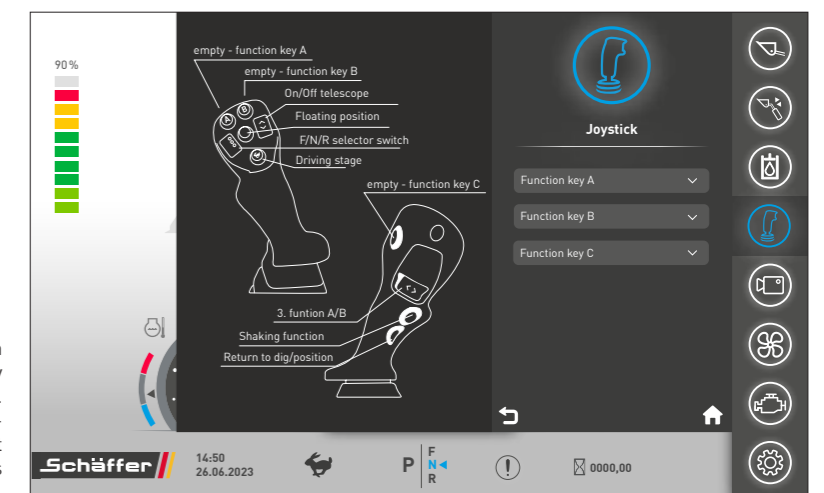

- Preview, layout will differ in the series version. -

In the joystick menu, three function buttons can be assigned individually depending on the machine equipment. At the same time, the button assignment can be read. The load display at the top left always remains visible, as does the status bar in the lower section.

8620 T-3 / 9640 T-3

HTF  SPT  ECO Mode  SDCT 
only 9640 T-3



YOUR SAFETY IS OUR PRIORITY

Our third generation telescopic wheel loaders are equipped with a dynamic load moment control according to DIN EN474-3, which constantly monitors your loading processes. The result? Working with the peace of mind that your safety comes first. An overload situation is avoided as the telescopic arm retracts automatically when being lowered. This ensures additional safety, even for inexperienced drivers.

In terms of lighting, we rely exclusively on high-intensity LED technology to illuminate your working environment to the maximum extent possible. Up to four LED spotlights at the front of the cabin and two more on the telescopic arm ensure optimal visibility. To the rear, the field of vision is illuminated perfectly by up to four headlights, optionally three headlights plus a beacon light.

Our telescopic wheel loaders are now equipped with split mirrors – wide-angle and close-up mirrors that improve your work safety.

We have once more optimised the engine compartment. The rear sloping bonnet contributes to a better view through the rear window, and a larger window in the roof ensures a better overview of the raised telescopic arm.



Up to four working headlights can be mounted on the front of the cabin.



To the rear, there is also space for up to four working headlights; alternatively, one headlight can be replaced by a beacon light.



The driving headlights are equipped with LEDs and daytime running light.



The rear sloping bonnet ensures a better view of the working area behind the machine.



Video 9660 T-2:
schaeffer.de/en/videos

9660 T-2: THE TELESCOPIC WHEEL LOADER WITH 6.10 M LIFTING HEIGHT

Schaeffer's range of telescopic wheel loaders with articulated joints is the most extensive on the market. With an operating weight up to 13 t and a lifting height of 6.10 m, the 9660 T-2 occupies an exclusive position. The 9660 T-2 is specially developed for the requirements of biogas plants and large scale farms and combines the good all round view and traction force of a standard wheel loader with the lifting height and reach of a conventional telescopic loader.

The 9660 T-2 has an operating weight of up to 13 t, the lifting capacity is approx. 5.3 t, making it our largest and most powerful machine. The single-stage telescopic arm

is robust enough to withstand even the toughest operating conditions. Ferro-Form sliding elements, as with all Schaeffer telescopic wheel loaders, promise a trouble-free telescoping process for many years to come.

The standard load sensing hydraulics provide up to 230 l/min and run very quickly even at low engine speeds. The 4-cylinder Deutz Common Rail turbo diesel engine with 130 kW (177 HP) or 150 kW (204 HP) works very efficiently as well. With a thrust of over 9,000 daN, the hydrostatic drive delivers the power needed even for the most demanding tasks.



The articulation joint is very strong and maintenance free. Two steering cylinders give perfect control.

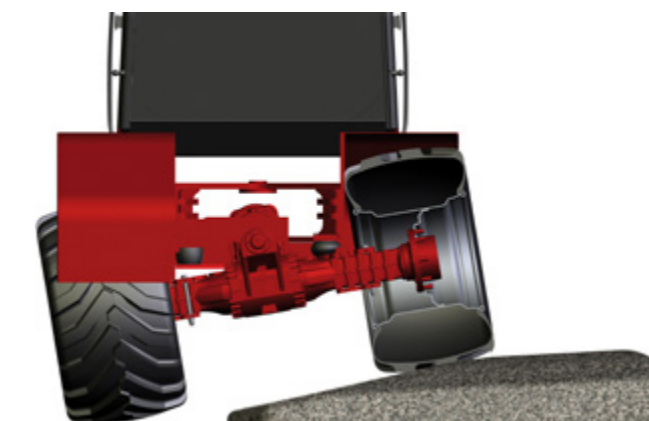

The rear axle is oscillating for best stability. The optional suspension gives safer and more comfortable operation.

9660 T-2: ADVANTAGES AT A GLANCE

SCV -Plus cab for best all round view and comfort. Deutz analysis system also included.

High capacity cooling system. Easy maintenance!

4-cyl. Deutz Common Rail diesel engine: powerful with 130 kW (177 HP) or 150 kW (204 HP)

1-stage telescopic boom with undestroyable Ferro-Form sliding elements.

Fast operating load sensing working hydraulics to 230 l/min at 220 bars. Pressure independent flow sharing.

Oscillating rear axle for best stability. Optional suspension for rear pendulum axle.

Optional with 'SDCT' and ECO Mode, 40 kph and high traction force: high thrust and maximum efficiency

24 t heavy-duty axles with multiple disc brakes and automatic limited slip differentials.



High Traction Force

- Very high thrust forces
- No need to manually shift down a gear when going uphill
- Even at high speed the maximum thrust is always available, e.g. when driving in muck heaps
- Enhanced driving comfort, faster working

HTF is standard equipment of all Schaffer telescopic wheel loaders.



Schaffer Power Transmission

- Higher efficiency, lower fuel consumption and reduced operating costs
- Extra safety functions including overheating and over rotation protection to make the loader safer and more reliable
- 'Start up assistant' to make hill starts easier
- Different parameters for different drive characteristics
- Optional potentiometer that works to maintain a constant speed regardless of the motor speed. This is particularly useful when working with feed dosing units, straw spreaders, mulchers or brooms (using pedal control on 9640 T-2 and 9660 T-2)
- Greater agility and more driving fun!

SPT is standard on the 2630 T SLT, 3650 T, 3650 T SLT, 4670 T-3, 5680 T-3, 6680 T-3 and 8620 T-3 is optionally available for the 96 series.



Schaffer Dual Clutch Transmission

- Huge level of thrust makes it easy to fill and move a mobile silo
- Most jobs can be carried out in a single operation, taking the strain off the clutch and the gearbox and thereby extending their service life
- Top speed of 40 kph, the best conditions even for usage in different areas of your business
- Fuel economy through increased machine efficiency, reduction in operating costs

SDCT is an available option for the telescopic wheel loaders of the 9600 series.



ECO Mode

- Fuel saving, reduction in operating costs
- Lower noise level
- Environmentally-friendly operation
- No restrictions on performance

ECO Mode is standard on the 3650 T, 3650 T SLT, 4670 T-3, 5680 T-3, 6680 T-3 and 8620 T-3 is optionally available for the 96 series.

TECHNICAL DATA

All technical specifications in this brochure refer to serial models and describe their standard functions. The equipment components and their functions as well as the accessories depend on the individual model and the product options and also on the country and customer specific requirements (the maximum values for tipping loads and payloads can only be reached with additional ballasting). Images may contain products or equipment components which are not mentioned or cannot be obtained as a standard. The descriptions, measurements, images, weight specifications and technical data correspond to the state of the art at the time of printing and are non-binding. We reserve changes in the field of construction, equipment, optics and technology without prior notice, due to the continuous development of the products. In case of doubts concerning the performance or the mode of operation of our products due to special circumstances, we recommend the execution of work samples under controlled conditions. We cannot exclude deviations from images or measurements, calculation errors, printing errors or incompleteness in the prospectus despite all due care. We do therefore not accept any liability for the correctness and completeness of the specifications in this prospectus. We do guarantee the proper functioning of our products within the scope of our General Terms and Conditions. Any guarantees that go beyond these are on principle not provided. Any liability beyond the ones set out in our General Terms and Conditions is excluded.

	2630 T SLT	3650 T	3650 T SLT	4670 T-3	5680 T-3
Engine	3-cyl. diesel engine Kubota D1703-M-Di, 18.5 kW (25 HP)	3-cyl. diesel engine Kubota D1803-CR-T (I), 37 / 42 kW (50 / 58 HP)	3-cyl. diesel engine Kubota D1803-CR-T, 37 kW (50 HP)	4-cyl. diesel engine Kubota V2403-CR-T, 48.6 kW (66 HP)	4-cyl. diesel engine Deutz TD 2.9, 55 kW (75 HP)
Exhaust gas treatment / emission level	- / V	DOC, DPF / V			
Traction hydraulics	hydrostatisch-automativ, HTF				
Tyres	31x15.5-15 AS	15.0/55-17 AS Option I: 425/55-17 Option II: 440/50-17	15.0/55-17 AS Option I: 425/55-17 Option II: 440/50-17	15.0/55-17 AS Option I: 425/55-17 Option II: 440/50-17	15.5/60-18 AT-621 Option I: 12.5/80-18 Option II: 425/55-17
Service braking system	Combined brake hydrostatic and multi-disc brake				
Parking brake	Multi-disc brake running in oil bath				
Working hydraulics Output/pressure	Delivery rate: 38 l/min Operating pressure: 220 bar	Delivery rate: from 51 l/min Operating pressure: 220 bar	Delivery rate: 51 l/min Operating pressure: 220 bar	Delivery rate: from 60 l/min Operating pressure: 220 bar	Delivery rate: from 64 l/min Operating pressure: 220 bar
Steering	Fully hydraulic articulated pendulum steering				Fully hydraulic articulated steering
Lifting capacity	1,600 kg	1,950 kg	1,950 kg	2,400 kg	2,400 kg
Tipping load, straight ¹	1,330 kg	1,710 kg	1,710 kg	2,110 kg	2,660 kg
Axles	Original Schäffer axles, 6-hole rim; Option: automatic slip-control differential	Original Schäffer axles, 6-hole rim; Option: automatic slip-control differential	Original Schäffer axles, 6-hole rim; Option: automatic slip-control differential	HD axles, 6-hole rim; planetary final drive and automatic slip-control differential, swing axle at rear	HD axles, 8-hole rim; planetary final drive and automatic slip-control differential, swing axle at rear
Operating weight	Protective roof: 2,750 kg Cabin: 2,815 kg	Protective roof: 3,600 kg Cabin: 3,800 kg	Protective roof: 3,700 kg	Protective roof: 3,900 kg Cabin: 4,000 kg	Cabin: 4,840 kg
Speed	20 kph in 2 gears switchable under load	20 kph in 2 gears switchable under load, Option: 30 kph	20 kph in 2 gears switchable under load, Option: 30 kph	20 kph in 2 gears switchable under load, Option: 30 kph	20 kph in 2 gears switchable under load, Option: 30 kph
Electric system	Operating voltage: 12 V				
Fill quantities	Fuel: 40 l Hydraulic oil: 30 l	Fuel: 55 l Hydraulic oil: 48 l	Fuel: 55 l Hydraulic oil: 48 l	Fuel: 95 l Hydraulic oil: 95 l	Fuel: 82 l Hydraulic oil: 81 l
Sound pressure level LpA	82 dB(A)	84 dB(A)	84 dB(A)	85 dB(A)	76 dB(A)
Sound power level guaranteed LwA equivalent LWA	101 db(A) 101 db(A)	101 db(A) 101 db(A)	101 db(A) 101 db(A)	101 db(A) 100 db(A)	101 db(A) 101 db(A)
Hand/arm vibration ²	< 2.5 m/s ²				
Total body vibration ²	< 0.5 m/s ²				

Tyre dimensions and additional equipment can change the operating weight, tipping load and payload.

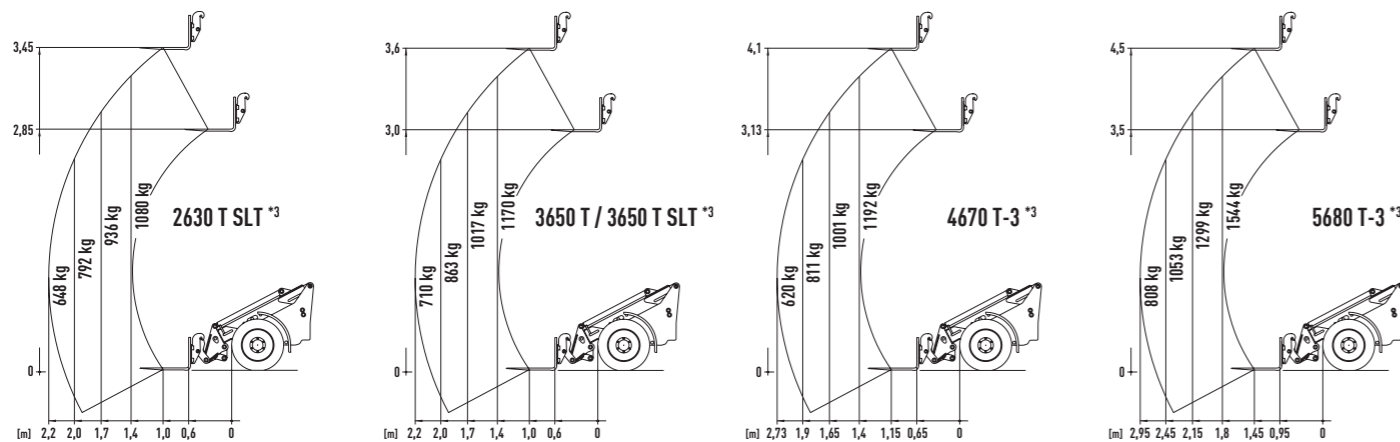

¹ boom horizontal, not extended, with pallet fork (acc. to ISO 14397) ² according to ISO 8041 ³ using forklifts on stable underground (according to EN 474-3)

	6680 T-3	8620 T-2	8620 T-3	9640 T-3	9660 T-2
Engine	4-cyl. diesel engine Deutz TCD 2.9, 55 kW (75 HP)	4-cyl. diesel engine Deutz TCD 3.6, 75 / 95 kW (102 / 129 HP)	4-cyl. diesel engine Deutz TCD 3.6, 105 kW (143 HP)	4-cyl. diesel engine Deutz TCD 5.2, 130 / 150 kW (177 / 204 HP)	
Exhaust gas treatment / emission level	DOC, DPF / V	DOC, DPF, SCR / V			
Traction hydraulics	hydrostatic-automotive, HTF				
Tyres	400/70-20 AS Option I 12.5/80-18 Option II 550/45-22.5	18-22.5 MP590 Option I: 400/70-20 Option II: 500/60-22.5 Option III: 600/40-22.5	460/70R24 AS Option I: 500/70R24 Option II: 600/50-26.5 Option III: 700/40-26.5	500/70R24 AS Option I: 600/55-26.5 Option II: 700/50-26.5 Option III: 650/55-26.5	
Service braking system	Combined brake hydrostatic and multi-disc brake				
Parking brake	Multi-disc brake running in oil bath				
Working hydraulics Output/pressure	Delivery rate.: from 76 l/min Operating pressure: 220 bar	Delivery rate.: from 106 l/min Operating pressure: 220 bar	Delivery rate.: 172 l/min Operating pressure: 220 bar	Delivery rate.: from 196 l/min Operating pressure: 220 bar	
Steering	Fully hydraulic articulated steering				
Lifting capacity	3,100 kg	4,200 kg	4,200 kg	5,300 kg	
Tipping load, straight ¹	3,820 kg	5,480 kg	5,940 kg	7,700 kg	
Axles	HD axles, 8-hole rim; planetary final drive and automatic slip-control differential, swing axle at rear	HD axles, 10-hole rim; planetary final drive and automatic slip-control differential, swing axle at rear	HD axles, 10-hole rim; planetary final drive and automatic slip-control differential, swing axle at rear	HD axles, 10-hole rim; planetary final drive and automatic slip-control differential, swing axle at rear	HD axles, 10-hole rim; planetary final drive and automatic slip-control differential, swing axle at rear
Operating weight	Cabin: 5,800 kg - 6,300 kg	Cabin: 7,050 kg - 7,950 kg	Cabin: 8,400 kg - 9,700 kg	Cabin: 11,000 kg - 13,000 kg	
Speed	20 kph in 2 gears switchable under load Option: 40 kph	20 kph in 2 gears switchable under load, Option: 40 kph	20 kph in 2 gears switchable under load, Option: 40 kph	30 kph (20 kph) in 2 gears switchable under load, Option: 40 kph	
Electric system	Operating voltage: 12 V				
Fill quantities	Fuel: 130 l Hydraulic oil: 120 l	Fuel: 150 l Hydraulic oil: 130 l	Fuel: 150 l Hydraulic oil: 130 l	Fuel: 185 l Hydraulic oil: 170 l	
Sound pressure level LpA	70 dB(A)	71 dB(A)	71 dB(A)	78 dB(A)	
Sound power level guaranteed LwA equivalent LWA	101 db(A) 101 db(A)	102 db(A) 101 db(A)	102 db(A) 102 db(A)	103 db(A) 101 db(A)	
Hand/arm vibration ²	< 2.5 m/s ²				
Total body vibration ²	< 0.5 m/s ²				

Tyre dimensions and additional equipment can change the operating weight, tipping load and payload.

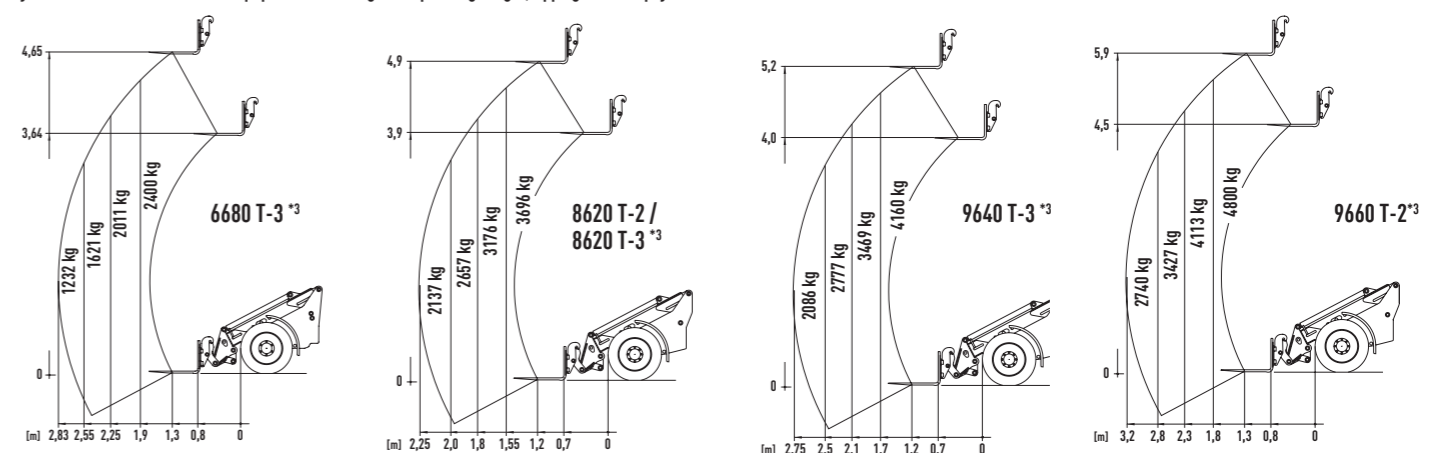

¹ boom horizontal, not extended, with pallet fork (acc. to ISO 14397) ² according to ISO 8041 ³ using forklifts on stable underground (according to EN 474-3)

DIMENSIONS

All technical specifications in this brochure refer to serial models and describe their standard functions. The equipment components and their functions as well as the accessories depend on the individual model and the product options and also on the country and customer specific requirements (the maximum values for tipping loads and payloads can only be reached with additional ballasting). Images may contain products or equipment components which are not mentioned or cannot be obtained as a standard. The descriptions, measurements, images, weight specifications and technical data correspond to the state of the art at the time of printing and are non-binding. We reserve changes in the field of construction, equipment, optics and technology without prior notice, due to the continuous development of the products. In case of doubts concerning the performance or the mode of operation of our products due to special circumstances, we recommend the execution of work samples under controlled conditions. We cannot exclude deviations from images or measurements, calculation errors, printing errors or incompleteness in the prospectus despite all due care. We do therefore not accept any liability for the correctness and completeness of the specifications in this prospectus. We do guarantee the proper functioning of our products within the scope of our General Terms and Conditions. Any guarantees that go beyond these are on principle not provided. Any liability beyond the ones set out in our General Terms and Conditions is excluded.

		2630 T SLT	3650 T	3650 T SLT	4670 T-3	5680 T-3
A	Wheelbase [mm]	1,900	1,920	1,920	2,000	2,120
B	Chassis length [mm]	3,850	4,070	4,070	4,200	4,691
C	Overall length with standard bucket [mm]	4,600	4,735	4,735	4,930	5,432
D	Digging depth [mm]	90	150	150	250	180
E	Reach [mm]	1,570	1,980	1,980	2,150	2,480
F	Max. bucket pivot point. [mm]	3,720	3,850	3,850	4,300	4,740
G	Loading height with pallet forks [mm]	3,470	3,580	3,580	4,080	4,499
H	Max. dumping height [mm]	3,010	3,010	3,010	3,480	3,862
I	Front end height [mm]	1,580	1,600	1,600	1,620	1,730
J	Dumping width [mm]	820	890	890	1,010	963
K	Seat height [mm]	955	1,180	1,080	1,300	1,330
L	Cab height [mm] Protective roof height [mm]	1,980 1,980	2,210 2,290	- 2,100	2,270 2,270	2,530 / 2,470 *1 -
M	Swivelling point, telescopic arm retracted [mm]	3,100	3,180	3,180	3,400	3,750
N	Overall width [mm]	1,410 - 1,590	1,420 - 1,730	1,420 - 1,730	1,420 - 1,730	1,720 - 1,820
O	Inner turning radius [mm]	1,240	1,290	1,290	1,425	1,740
P	Outer turning radius [mm]	2,740	2,710	2,710	2,845	3,460
Q	Outer radius with standard bucket [mm]	3,040	3,060	3,060	3,425	3,980

		6680 T-3	8620 T-2	8620 T-3	9640 T-3	9660 T-2
A	Wheelbase [mm]	2,450		2,535	2,615	2,900
B	Chassis length [mm]	5,050		5,114	5,452	5,900
C	Overall length with standard bucket [mm]	5,780		6,031	6,260	6,950
D	Digging depth [mm]	50		75	70	80
E	Reach [mm]	2,360		2,660	2,860	3,300
F	Max, bucket pivot point, [mm]	4,950		5,200	5,400	6,100
G	Loading height with pallet forks [mm]	4,700		4,960	5,178	5,900
H	Max, dumping height [mm]	3,980		4,350	4,574	5,100
I	Front end height [mm]	1,750		1,910	1,960	2,190
J	Dumping width [mm]	815		650	740	850
K	Seat height [mm]	1,470		1,660	1,650	1,880
L	Cab height [mm]	2,630 / 2,530 *1	2,770 / 2,670 *1	2,770	2,830	2,900
M	Swivelling point, telescopic arm retracted [mm]	3,950		4,085	4,100	4,800
N	Overall width [mm]	1,840 - 2,090		2,060 - 2,260	2,330 - 2,380	2,290 - 2,490
O	Inner turning radius [mm]	1,960		2,310	2,220	2,910
P	Outer turning radius [mm]	3,760		4,390	4,560	5,200
Q	Outer radius with standard bucket [mm]	4,400		4,920	5,110	5,650

*1 Option: low cabin

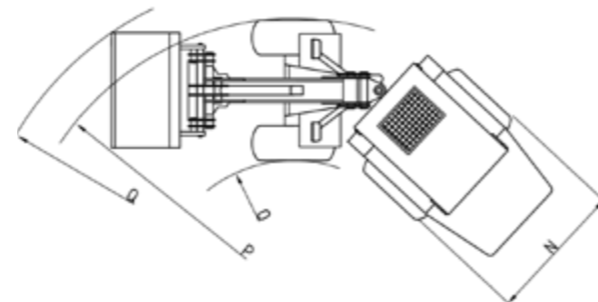
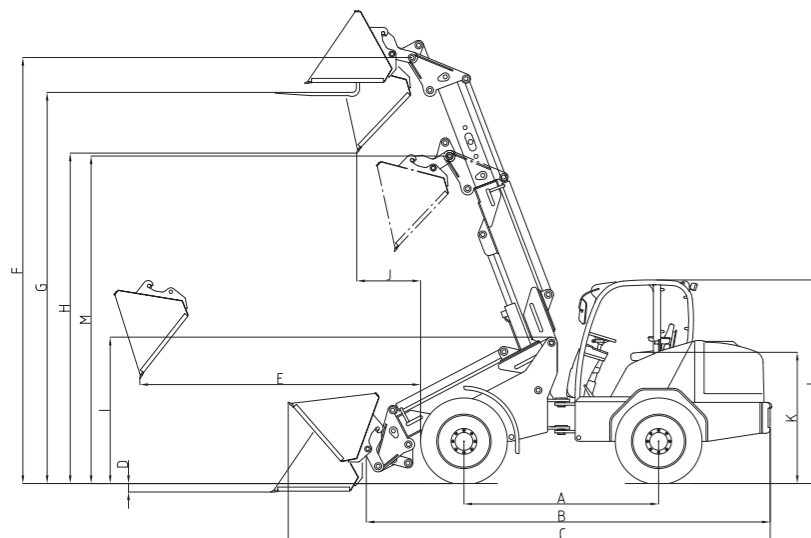

Availability of Schäffer efficiency systems

	2630 T SLT	3650 T	3650 T SLT	4670 T	5680 T	6680 T	8620 T	9640 T	9660 T
HTF	X	X	X	X	X	X	X	X	X
SPT	X	X	X	X	X	X	X	O	O
eco Mode	-	X	X	X	X	X	X	O	O
SDCT	-	-	-	-	-	-	-	O	O

X = as standard, O = optional



MADE FOR MORE.

Because we know: If you want more, you need more than just standard. That is why we at Schäffer never settle for the first thing that comes along. We think ahead and have been developing machines that truly make a difference in the real world for 70 years. Machines that offer more performance, more quality and more reliability for everyone who depends on powerful technology every day.

Over 45 machine types and more than 1,000 tool variants provide you with maximum flexibility, be it as a farmer, construction professional or recycling expert. Our loaders are compact, powerful and efficient and capable of handling tasks that typically demand much larger machines.

Trust in genuine “Made in Germany” quality – manufactured in Erwitte, with an exceptionally high vertical range of manufacture. Schäffer relies on robust materials and high-quality components. From specially developed axles and solid articulated joints to countless thoughtful details, every element ensures maximum stability and reliability, even in the most demanding conditions. Some features that are not available elsewhere or are only available at extra cost come standard with Schäffer.

YOUR DEALER:

Specially developed technologies and efficiency systems noticeably enhance performance and driving comfort, boosting productivity for every application.

A Schäffer machine represents unmatched product quality and long-term cost-effectiveness. Durable components, low wear, significantly reduced fuel consumption and minimal maintenance ensure consistently low operating costs.

At the same time, our machines also stand out for their high value retention and a reliable spare parts supply, with 24-hour delivery available 365 days a year.

